

Servo right-angle gearheads High End



RPK+

Around corners with power and precision

- Low backlash hypoid gearhead with output flange
- Cyclic operation
- Torsional backlash: ≤ 1 arcmin
- Ratio: 48-5,500

Product highlights:

- High torsional rigidity
- High axial and radial forces
- Easy installation
- Optimized for rack and pinion applications



TK+, TPK+ and TPK+ HIGH TORQUE

Space-saving right-angle precision with output flange

- Low backlash right-angle gearhead with output flange
- Applications in cyclic or continuous operation
- Torsional backlash: ≤ 1.3 arcmin
- Ratio: 3-10,000

Product highlights:

- Large range of ratios
- High torque capacity (MA)
- Optionally available as a hollow shaft version
- Flexibility thanks to various output configurations



SK+ and SPK+

Space-saving right-angle precision with output shaft

- Low backlash hypoid gearhead with output shaft
- Applications in cyclic or continuous operation
- Torsional backlash < 2 arcmin
- Ratio: 3-10,000

Product highlights:

- Diverse range of transmission ratios
- Flexibility thanks to various types of output

Power density ←

Increased productivity

Do you need a machine that operates at maximum productivity? Your servo right-angle gearhead offers 200% more torque, 100% faster speeds than equivalent products and thus creates the perfect conditions for maximum manufacturing efficiency.

Simple and convenient

From an optimized design with our cymex® software to the classic, patented WITTENSTEIN alpha motor mounting and oil/grease volume adapted to each model – WITTENSTEIN alpha right-angle gearheads make your life so much easier.



HG+

Precise hollow shaft solution

- Low backlash hypoid gearhead with hollow shaft
- Applications in cyclic or continuous operation
- Torsional backlash: ≤ 4 arcmin
- Ratio: 3-100

Product highlights:

- Hollow shaft version
- Flexibility thanks to various types of output

SC+ / SPC+ / TPC+

High performance with low ratios

- Low backlash bevel gears with output shaft or output flange
- Applications in cyclic or continuous operation
- Torsional backlash ≤ 2 arcmin
- Ratio: 1-20

Product highlights:

- High power density
- High output speeds
- Efficiency 97%

V-Drive+

Strong torque but quiet running

- Low backlash servo worm gearhead with output shaft, hollow shaft and hollow shaft flange
- Applications in cyclic or continuous operation
- Torsional backlash: ≤ 2 arcmin
- Ratios: 4-40

Product highlights:

- Hollow shaft version
- Single-stage up to $i=40$
- Smooth running
- Good synchronization

Reliable and accurate

The low torsional backlash and high torsional rigidity of your WITTENSTEIN alpha right-angle gearhead assure maximum positioning accuracy of your drives and precision of your machines – even during highly dynamic operation up to 50,000 cycles/hour.

Maximum durability

Your WITTENSTEIN alpha right-angle gearhead is extremely reliable due to the overall design and 100% WITTENSTEIN alpha inspections: **“mount and forget”**. A length compensation feature integrated in your WITTENSTEIN alpha right-angle gearhead as standard maximizes the lifespan of your servo motor during high-speed continuous operation.

Right-angle gearheads High End	
	RPK
	TK+ / TPK
	SK+ / SPK
	HG+
	SC+ / SPC+ / TPC+
	V-Drive+

RPK+ – Around the corner with power and precision

Sets standards in terms of power density, modularity and easy installation.



The new standard, also available as a right-angle version

Low backlash hypoid gearhead with output flange. The RPK+ impresses through its extremely high torsional rigidity, compactness and power density. Thanks to their easy installation and ability to absorb high axial and radial forces, these gearheads are ideal for rack and pinion applications.

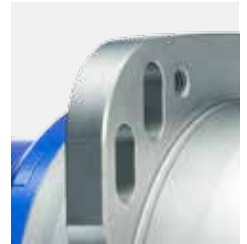

The RPK+ impresses with maximum power density

- If your drive requires maximum performance
- If you value world-class engineering
- If you require an even more compact system

Performance data for right-angle version

Torsional backlash [arcmin]	< 3
Ratios [-]	66-5,500
Max. torque [N]	10,000
Max. input speed [rpm]	6,000
Efficiency [%]	≤ 92



The geometry of the RPK+ output flange is perfectly adapted to the high power density.



The RPK+ high performance right-angle gearhead is optimized for rack and pinion applications.

High Performance Linear System

For use where the individual requirements far exceed what has previously been possible. Compared to the industry standard, the values have been improved by 150% on average!

The integrated slots reduce the design and installation requirements to a minimum.

The pinions, which are specially adapted to the gearhead enable the transmission of maximum moving forces.

Further information is available in the High Performance Linear System catalog or on the Internet at www.rack-pinion.com

Performance data for linear system

Positioning accuracy [µm]	< 5*
Ratios [-]	66-5,500
Max. moving force per drive [N]	112,000
Movement speed [m/min]	30
Efficiency [%]	≤ 92

* Direct measuring system required

Flexibility during installation

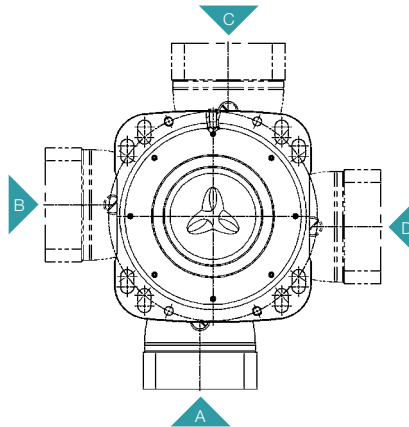

Right-angle gearheads
High End



RPK



The RP* is also available as the RPM* actuator version. The RPM* combines the advantages of the RP* series in an even more compact design. Thanks to its special design, the permanently excited servo motor ensures maximum power density.



Sets standards in terms of power density, modularity and easy installation.